

# ELECTRO-HEAT, INC.

PRINT THIS FORM & FAX IT TO US AT (269) 673-6689 FOR A QUOTATION

## ENGINEERING SPECIFICATIONS

### ALUMINUM FIN TUBE CARTRIDGE HEATER

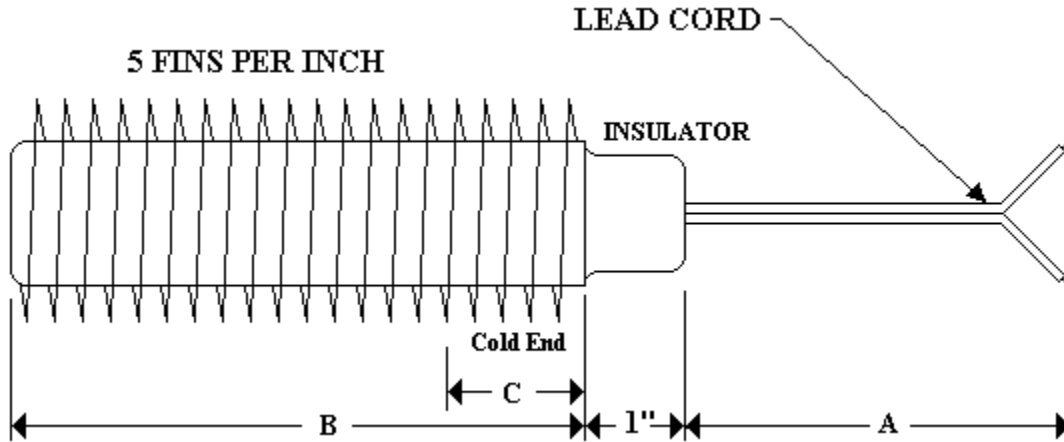

VOLTS: \_\_\_\_\_

WATTS: \_\_\_\_\_

"A" DIMENSION: \_\_\_\_\_

"B" DIMENSION: \_\_\_\_\_

"C" DIMENSION: \_\_\_\_\_

LEAD CORD: \_\_\_\_\_

OTHER APPLICATION INFORMATION

# ELECTRO-HEAT, INC.

PRINT THIS FORM & FAX IT TO US AT (269) 673-6689 FOR A QUOTATION

## ENGINEERING SPECIFICATIONS STAINLESS STEEL CARTRIDGE HEATER

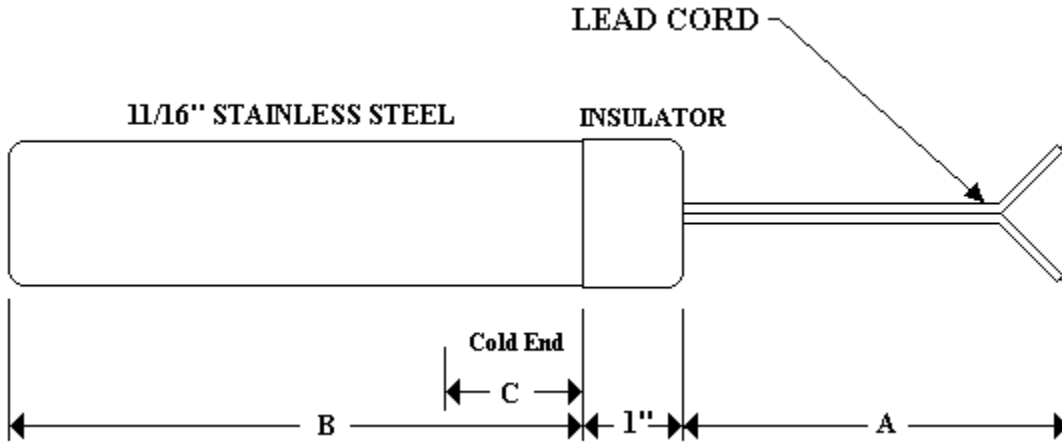

VOLTS: \_\_\_\_\_

WATTS: \_\_\_\_\_

"A" DIMENSION: \_\_\_\_\_

"B" DIMENSION: \_\_\_\_\_

"C" DIMENSION: \_\_\_\_\_

LEAD CORD: \_\_\_\_\_

OTHER APPLICATION INFORMATION